

**GARMIN®**

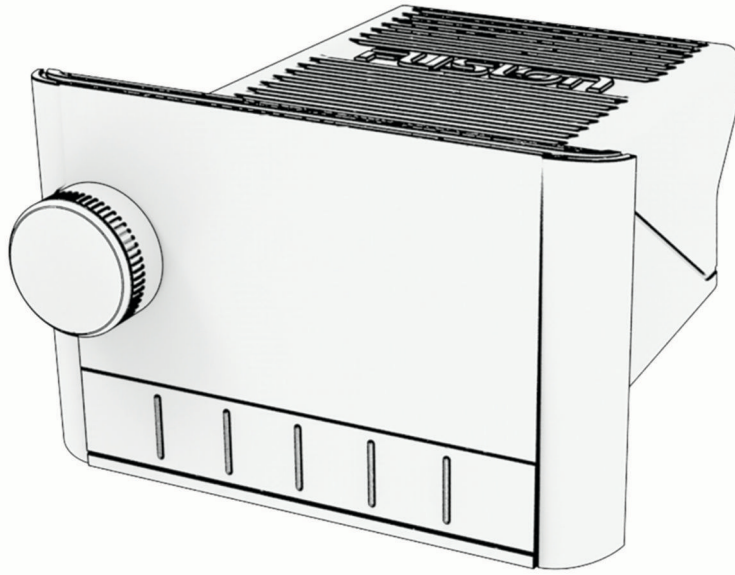

# APOLLO™ MS-SRX400

---

Owner's Manual

© 2020 Garmin Ltd. or its subsidiaries

All rights reserved. Under the copyright laws, this manual may not be copied, in whole or in part, without the written consent of Garmin. Garmin reserves the right to change or improve its products and to make changes in the content of this manual without obligation to notify any person or organization of such changes or improvements. Go to [www.garmin.com](http://www.garmin.com) for current updates and supplemental information concerning the use of this product.

Garmin®, Fusion®, and the Fusion logo are trademarks of Garmin Ltd. or its subsidiaries, registered in the USA and other countries. Apollo™, and Fusion PartyBus™ are trademarks of Garmin. These trademarks may not be used without the express permission of Garmin.

Apple®, AirPlay®, and App Store™ are trademarks of Apple Inc. Android™ and Google Play™ are trademarks of Google Inc. BLUETOOTH® word mark and logos are owned by the Bluetooth SIG, Inc. and any use of such marks by Garmin is under license. Wi-Fi® is a registered mark of Wi-Fi Alliance Corporation. Other trademarks and trade names are those of their respective owners.

M/N: MS-SRX400, A03460

# Table of Contents

<b>Getting Started</b> .....	<b>1</b>
Stereo Controls.....	1
Entering Text.....	2
Using the Dial to Select Items.....	2
Stereo Screen.....	3
Naming the Device.....	3
Selecting a Source.....	3
Adjusting the Backlight Brightness.....	4
<b>Audio Control</b> .....	<b>4</b>
Adjusting the Volume.....	4
Muting all Connected Stereos.....	4
Adjusting the Subwoofer Level.....	4
Adjusting the Tone.....	4
Disabling the Loud Setting.....	4
DSP Settings.....	5
Configuring the DSP Settings.....	5
<b>Media Player Connection</b> .....	<b>5</b>
<b>Bluetooth Device Playback</b> .....	<b>5</b>
Connecting a Compatible Bluetooth Device.....	6
Bluetooth Range Information.....	6
Selecting a Different Bluetooth Device.....	6
Bluetooth Source Menu and Settings....	7
Disabling Bluetooth Auto Connection.....	7
<b>Radio</b> .....	<b>7</b>
Setting the Tuner Region.....	7
Changing the Radio Station.....	8
<b>Apple AirPlay</b> .....	<b>8</b>
Connecting an Apple Device Using AirPlay.....	8
Setting an AirPlay Password.....	8
<b>Fusion PartyBus Networking</b> .....	<b>9</b>
Creating a Group.....	9
Editing a Group.....	9
Leaving a Group.....	9
Grouped Stereo Functions.....	10
Grouped Stereo Source Considerations.....	10
Group Synchronization.....	11
Enabling Group Synchronization.....	11
<b>General Settings</b> .....	<b>12</b>
Speaker Zone Settings.....	12
Disabling the Internal Amplifier.....	12
Setting the Home Zone.....	12
Adjusting the Power-On Volume Limit.....	12
Maintaining Individual Zone Volume Levels.....	13
Setting a Zone Name.....	13
Adjusting the Subwoofer Filter.....	13
Adjusting Additional Audio Settings for a Zone.....	13
Power Options.....	13
Source Settings.....	14
Network Settings.....	14
Connecting the Fusion PartyBus Device to a Wireless Access Point...	14
Connecting the Device to a Wireless Access Point Using Wi-Fi Protected Setup.....	14
Connecting the Device to a Wireless Access Point Using Apple Wireless Accessory Configuration.....	15
Setting the Fusion PartyBus Device as a Wireless Access Point.....	15
Wireless Access Point Settings....	16
Advanced Network Configuration....	16
Setting the Fusion PartyBus Device as the DHCP Server.....	17
Connecting the Stereo to a Garmin Network.....	17
Setting a Static IP Address.....	18
Resetting Network Settings.....	18
<b>Additional Stereo Control Options</b> ...	<b>18</b>
Fusion Audio Wireless Remote Control App.....	18
Fusion Stereo Network Connection and Control.....	19
<b>Appendix</b> .....	<b>19</b>
Registering Your Fusion Device.....	19
Cleaning the Device.....	19

- Software Updates..... 19
  - Updating the Software Using the Fusion Audio App..... 20
  - Network Update Options..... 20
- Troubleshooting..... 20
  - The stereo does not respond to key presses..... 20
  - My Bluetooth audio is interrupted by short breaks..... 21
  - The stereo does not display all song information from my Bluetooth source..... 21
  - Network Troubleshooting..... 21
    - Network Status Icons..... 22
  - The stereo keeps locking up when connected to an Apple device..... 22
  - The stereo is not finding my connected Apple device..... 22
  - My Apple AirPlay audio is interrupted by short breaks..... 22
- Specifications..... 23
- Stereo Dimension Drawings..... 24
  - Side Dimensions..... 24
  - Top Dimensions..... 25





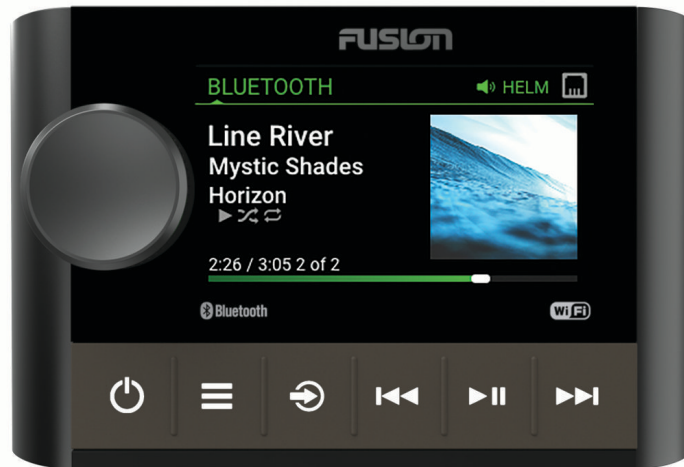

# Getting Started

## ⚠ WARNING

See the *Important Safety and Product Information* guide in the product box for product warnings and other important information.





## Stereo Controls



	<ul style="list-style-type: none"> <li>• Turn to adjust the volume.</li> <li>• Turn to move through the menus or adjust a setting.</li> </ul>
Dial	<ul style="list-style-type: none"> <li>• When in a menu, press to select the highlighted option.</li> <li>• Press and hold to activate certain functions such as opening the radio presets or muting all connected stereos from the mute screen (<i>Muting all Connected Stereos, page 4</i>).</li> </ul>
	<ul style="list-style-type: none"> <li>• Press to turn on the stereo.</li> <li>• Press to mute the audio.</li> <li>• Press and hold to turn off the stereo or all stereos on the network.</li> <li>• Press and hold for longer than 10 seconds to reset the stereo.</li> </ul>
	<ul style="list-style-type: none"> <li>• Press to open the menu.</li> <li>• Press to return to the previous screen from the menu.</li> <li>• Press and hold to exit the menu.</li> </ul>
	<p>Press to change the source.</p> <p><b>TIP:</b> You can turn the dial to browse, and press the dial to select the source.</p> <p>Press and hold to open the GROUPS menu when connected to a Fusion PartyBus™ network (<i>Fusion PartyBus Networking, page 9</i>).</p>
	<ul style="list-style-type: none"> <li>• Press to skip to the beginning of the track or to the previous track, when using an applicable source.</li> <li>• Press and hold to rewind the track, when using an applicable source.</li> <li>• AM/FM: <ul style="list-style-type: none"> <li>◦ Press to tune to the previous station or preset.</li> <li>◦ Press and hold for faster tuning (manual mode only).</li> </ul> </li> </ul>
	<ul style="list-style-type: none"> <li>• Press to pause or resume the current track, when using an applicable source.</li> <li>• AM/FM: <ul style="list-style-type: none"> <li>◦ Press to cycle through the tuning modes (auto, manual, and presets).</li> <li>◦ Press and hold to save the current station as a preset.</li> </ul> </li> </ul>
	<ul style="list-style-type: none"> <li>• Press to skip to the next track, when using an applicable source.</li> <li>• Press and hold to fast-forward the track, when using an applicable source.</li> <li>• AM/FM: <ul style="list-style-type: none"> <li>◦ Press to tune to the next station or preset.</li> <li>◦ Press and hold for faster tuning (manual mode only).</li> </ul> </li> </ul>

For information about controlling sources from a grouped stereo, see that stereo's owner's manual.

## Entering Text

- 1 In a field that allows you to enter text, select  to erase the existing characters.
- 2 If necessary, select  or  to use numerals, symbols, or lower-case letters when available.
- 3 Turn the dial to choose a character, and press the dial to select it.
- 4 Select  to save the new text.

## Using the Dial to Select Items

You can use the dial to highlight and select items on the screen.

- Turn the dial to highlight an item on the screen.
- Press the dial to select the highlighted option.

## Stereo Screen

The information displayed on the screen varies depending on the source selected. This example shows a track playing on a device connected using Bluetooth® wireless technology.



①	Source name
②	Active zone and status icons ( <a href="#">Network Status Icons, page 22</a> )
③	Track details (if available)
④	Album art (if available from a compatible source)
⑤	Elapsed time, track duration, and the current track number out of the total number of tracks in the playlist (if available)

## Naming the Device

You should provide a unique name for this device so you can easily identify it when viewing devices on the Fusion PartyBus network.

**NOTE:** You should provide unique names for all of the devices and zones on the network to avoid confusion when grouping, controlling, and setting up stereos and zones.

For further customization, you can provide unique names for the sources on each stereo and turn off unused sources ([General Settings, page 12](#)).

- 1 Select  > **SETTINGS**.
- 2 Select **DEVICE NAME**, and select an option:
  - Select a pre-defined name from the list.
  - Select **CUSTOM NAME**, and enter a unique name for the device.

## Selecting a Source

- 1 Select .
- 2 Turn the dial to highlight a source.

**NOTE:** If the device is part of a group, continue turning the dial to access the sources on other devices in the group ([Creating a Group, page 9](#)).

If a source cannot be shared with the group, it will appear gray and you cannot select it.
- 3 Press the dial to select the source.

## Adjusting the Backlight Brightness

**NOTE:** If you connected the dim wire on the wiring harness to the boat's illumination wire, the backlight dims automatically when the boat lights are on. This may affect how you adjust the brightness setting.

- 1 Select  > **BRIGHTNESS**.
- 2 Adjust the brightness level.

# Audio Control

## Adjusting the Volume

Using this stereo, you can control the volume of any zone on any stereo connected to the Fusion PartyBus network.

- 1 Turn the dial to adjust the volume for the home zone on the stereo.
- 2 If necessary, press the dial to switch between zones.

**NOTE:** If this stereo is part of a group, you can adjust the volume of all stereos in the group or individual zones on each stereo ([Creating a Group, page 9](#)).

## Muting all Connected Stereos

You can quickly mute the audio from this stereo or from all stereos connected to the Fusion PartyBus network ([Fusion PartyBus Networking, page 9](#)).

- 1 From any source, press .  
The mute symbol appears and audio from this stereo is silenced.  
**NOTE:** If the stereo is part of a group, the audio from all grouped stereos is silenced.
- 2 Press and hold the dial to select **MUTE SYSTEM**.  
Audio from all connected stereos is silenced.
- 3 Press and hold the dial to select **UNMUTE SYSTEM**.  
Audio is restored to all connected stereos.

## Adjusting the Subwoofer Level

You can adjust the subwoofer level for each zone.

- 1 Press the dial, and select a zone with a connected subwoofer.
- 2 Press and hold the dial.  
The SUB LEVEL adjustment for the zone appears.
- 3 Adjust the subwoofer level and press the dial to set it.

## Adjusting the Tone

- 1 Select  > **AUDIO** > **ZONE 1**.
- 2 Press the dial to select a tone.
- 3 Adjust the tone level and press the dial to set it.

## Disabling the Loud Setting

The LOUD setting maintains frequency response at low volumes and increases perceived loudness at high volumes. This setting is enabled by default.

- 1 Select  > **AUDIO** > **ZONE 1**.
- 2 Select **LOUD** to clear the check box.



## DSP Settings

This stereo features digital signal processing (DSP). You can select pre-configured DSP settings for Fusion® speakers and amplifiers to optimize audio reproduction in their installed locations.

The stereo uses the same DSP setting for the speakers connected to the internal amplifier and for the line out connection. If you connected speakers to the internal amplifier and are using the line out, the DSP setting might cause the speaker output to be more limited than necessary.

All DSP settings are configured using the Fusion Audio remote control app ([Fusion Audio Wireless Remote Control App, page 18](#)).

### Configuring the DSP Settings

You must download and install the Fusion Audio remote control app on your compatible Apple® or Android™ device before you can configure the DSP settings ([Fusion Audio Wireless Remote Control App, page 18](#)).

You can configure the DSP settings to optimize the sound on each zone with the installed speakers, amplifiers, and environment.

- 1 From the settings menu on your Apple or Android device, connect to the stereo using Bluetooth technology or connect to the same wireless network as the stereo.
- 2 Open the Fusion Audio remote control app on your compatible Apple or Android device.
- 3 If necessary, select the stereo you want to configure.
- 4 Select .
- 5 If necessary, select the **MUSIC** tab.
- 6 Select a zone.
- 7 Select **DSP SETTINGS**.
- 8 Configure the DSP settings as needed, depending on the models of Fusion speakers and amplifiers connected to the zone.
- 9 Select **SEND DSP SETTINGS**.  
**NOTE:** DSP settings or updates for the zone are not applied on the stereo until you select the button to send the settings.
- 10 Repeat these steps for each zone.

## Media Player Connection

### WARNING

Minimize interaction with the media player display while operating the vessel, because doing so can cause distraction that could lead to an accident resulting in serious personal injury or death.

### NOTICE

Always disconnect your media player from the stereo when not in use and do not leave it in your vessel. This can help reduce the risk of theft and damage from extreme temperatures.

The stereo accepts a variety of media players, including smartphones and other mobile devices. The stereo can play media from a compatible Apple device connected to the same network using the AirPlay® feature.

## Bluetooth Device Playback

You can pair the stereo to up to eight Bluetooth media devices.

You can control the playback using the stereo controls on all Bluetooth devices, and on some devices you can browse the music collection from the menu on the stereo.

On Bluetooth devices that do not support media browsing, you should select the song or playlist on the media device.

The availability of song information such as song title, artist name, track duration, and album art depends on the capability of the media player and music application.

## Connecting a Compatible Bluetooth Device

You can play media from a compatible Bluetooth device using the Bluetooth wireless connection.

You can control the music playback with the media app on a Bluetooth device or using the Fusion Audio remote control app (*Fusion Audio Wireless Remote Control App*, page 18).

- 1 Select the **BLUETOOTH** source.
- 2 Select  > **BLUETOOTH** > **CONNECTIONS** > **DISCOVERABLE** to make the stereo visible to your compatible Bluetooth device.
- 3 Enable Bluetooth on your compatible Bluetooth device.
- 4 Bring the compatible Bluetooth device within 10 m (33 ft.) of the stereo.
- 5 On your compatible Bluetooth device, search for Bluetooth devices.
- 6 On your compatible Bluetooth device, select the stereo from the list of detected devices.  
**NOTE:** The stereo appears in the Bluetooth device list as the device name (the default name is MS-SRX400 unless it was changed in the settings).
- 7 On your compatible Bluetooth device, follow the on-screen instructions to pair and connect to the discovered stereo.  
When pairing, your compatible Bluetooth device may ask you to confirm a code on the stereo. The stereo does not display a code, but it does connect correctly when you confirm the message on the Bluetooth device.
- 8 If your compatible Bluetooth device does not immediately connect to the stereo, repeat steps 1 through 7.  
**NOTE:** If another Bluetooth device is already playing music on the stereo, connecting a new device will not interrupt playback. You must select the newly-added device if you want to use it instead (*Selecting a Different Bluetooth Device*, page 6).

The DISCOVERABLE setting is disabled automatically after two minutes.

**NOTE:** On some Bluetooth devices, adjusting the volume on the device affects the volume level on the stereo.

### Bluetooth Range Information

The stereo and Bluetooth wireless devices have a range of 10 m (33 ft.). For optimal performance, the Bluetooth wireless device should also have a clear line of sight to the stereo.

**NOTE:** Wi-Fi® signals may interfere with Bluetooth device connections. You should turn off the Wi-Fi setting on your stereo if you are not using it.

### Selecting a Different Bluetooth Device

When you have more than one Bluetooth device paired to the stereo, you can select a different device when needed. You can pair the stereo with up to eight Bluetooth devices.

- 1 With the **BLUETOOTH** source selected, select  > **BLUETOOTH** > **CONNECTIONS** > **PAIRED DEVICES**.
- 2 Select a Bluetooth device.

## Bluetooth Source Menu and Settings

With the BLUETOOTH source selected, select  > **BLUETOOTH**.

**NOTE:** The options in this menu vary based on the connected device.

**CONNECTIONS > DISCOVERABLE:** Allows the stereo to be visible to Bluetooth devices. You can turn off this setting to prevent possible interruption to audio after pairing a Bluetooth device to the stereo.

**CONNECTIONS > PAIRED DEVICES:** Shows a list of Bluetooth devices paired with the stereo. You can select a device in the list to connect it to the stereo if it is in range.

**CONNECTIONS > REMOVE DEVICE:** Removes the Bluetooth device from the stereo. To listen to audio from this Bluetooth device again, you must pair the device again.

**NOTE:** You should also remove the stereo from the list of paired devices on your Bluetooth device to avoid connection issues when pairing the device again.

**REPEAT:** Sets the repeat mode for the current selection (Apple devices only). You can repeat the current selection by selecting the REPEAT ONE option. You can repeat all items in the selection by selecting the REPEAT ALL option.

**SHUFFLE:** Shuffles the tracks in the folder, album, or playlist (Apple devices only).

**PLAYLIST:** Displays the playlists on the device (Apple devices only).

**ARTISTS:** Displays the artists on the device (Apple devices only).

**ALBUMS:** Displays the albums on the device (Apple devices only).

**GENRES:** Displays the genres of music on the device (Apple devices only).

**SONGS:** Displays the songs on the device (Apple devices only).

**APPLE MUSIC RADIO:** Displays the Apple Music Radio stations on the device (Apple devices only).

## Disabling Bluetooth Auto Connection

By default, the stereo automatically reconnects to the last connected Bluetooth device when you turn it on. You can disable this setting.

Select  > **SETTINGS** > **SOURCE** > **BLUETOOTH** > **AUTO CONNECT**.

When the AUTO CONNECT checkbox is clear, the stereo will not attempt to automatically reconnect to a Bluetooth device. When this feature is disabled, you must select a Bluetooth device manually to connect it ([Selecting a Different Bluetooth Device, page 6](#)).

## Radio

To listen to AM or FM radio, you must have a suitable marine AM/FM antenna properly connected to the stereo and be within range of a broadcasting station. For instructions on connecting an AM/FM antenna, see the stereo installation instructions.

## Setting the Tuner Region

You must select the region you are in to receive AM and FM stations properly.

- 1 Select  > **SETTINGS**.
- 2 Select **TUNER REGION**.
- 3 Select the region you are in.



## Changing the Radio Station

- 1 Select an applicable source, such as **FM**.
- 2 Select **▶||** repeatedly to move through the tuning modes, and select an option:
  - Select **AUTO** to scan and stop on the next available station.
  - Select **MANUAL** to select a station manually.
  - Select **PRESET** to select a saved station preset.
- 3 Select **◀◀** or **▶▶** to tune to the station.

When in **MANUAL** tuning mode, you can hold **◀◀** or **▶▶** to quickly advance through the stations.

## Apple AirPlay

### Connecting an Apple Device Using AirPlay

- 1 From the settings menu on your Apple device, connect to the same wireless network as your compatible Fusion stereo.  
**NOTE:** You can connect some Apple devices to the network using a wired Ethernet connection, if applicable. Go to the Apple website for more information.
- 2 On your Apple device, open the music app you want to stream to the stereo.
- 3 From the music app or program, select  or , and select the name of the stereo.
- 4 If necessary, start playing music on the app.

The stereo changes to the **AIRPLAY** source automatically and plays audio from your Apple device.

**NOTE:** If your Apple device is using AirPlay 2 software, you can connect to multiple stereos on the same network.

**NOTE:** You cannot stream the **AIRPLAY** source to other stereos on the network using the Fusion PartyBus network (*Fusion PartyBus Networking*, page 9). Using AirPlay 2 software, you can play content on multiple stereos on the network, but the stereos must not be grouped.

**NOTE:** On some AirPlay devices, adjusting the volume on the device affects the volume level on the stereo.

### Setting an AirPlay Password

You can set a password that a user must enter when connecting to the stereo using the AirPlay feature.

- 1 Select  > **SETTINGS** > **SOURCE** > **AIRPLAY** > **AirPlay PASSWORD**.
- 2 Enter a password.

**NOTE:** The AirPlay password is case-sensitive.

When connecting to this stereo using the AirPlay feature, the user must enter the password on their Apple device.

# Fusion PartyBus Networking

The Fusion PartyBus networking feature allows you to connect multiple compatible stereos together on a network, using a combination of wired or wireless connections.

**NOTE:** When you connect a Fusion stereo to Garmin BlueNet™ network or a Garmin® Marine Network, you are limited to using only Garmin and Fusion devices. You may not be able to use third-party routers, storage devices, or other network products with this stereo directly.

**TIP:** When the stereo is connected to a Garmin BlueNet network or a Garmin Marine Network, you can connect a mobile device to a wireless access point on a connected Garmin chartplotter and use the Fusion Audio app to control the stereo.

You cannot use Wi-Fi networking when a stereo is connected to a Garmin network.

You can group a compatible stereo, such as the Apollo RA770 stereo, with other compatible stereos connected to the Fusion PartyBus network. Grouped stereos can share available sources and control media playback on all of the stereos in the group, which allows for a synchronized audio experience across the vessel. You can quickly create, edit, and break up groups as needed from any compatible stereo or remote control on the network.

You can use compatible stereos and remote controls, whether they are grouped or not, to adjust the volume of the available speaker zones for any stereo on the network.

You should refer to the installation instructions provided with your stereo when constructing the Fusion PartyBus network.

You can connect up to eight Fusion PartyBus stereos on a network wirelessly.

## Creating a Group

Before you can create a group, you must connect multiple compatible stereos to the Fusion PartyBus network. See the installation instructions provided with your stereo for information about installing and configuring the network.

**NOTE:** There are some limitations and other considerations when using stereos in groups. See [Grouped Stereo Source Considerations, page 10](#) for more information.

1 Select  > **GROUPS**.

**TIP:** You can hold  from any screen to open the GROUPS menu.

2 Select the name of the stereo you want to be the primary stereo in the group.

3 Select the stereos you want to add to the group.

4 Select **DONE**.

From the source screen, you can select a source from any stereo in the group except a zone stereo, such as the Apollo SRX400 stereo or any sources that are disabled for use on the Fusion PartyBus network ([General Settings, page 12](#)).

## Editing a Group

1 Select  > **GROUPS**.

2 Select the group.

3 Select the stereos you want to add to or remove from the group.

4 Select **DONE**.

## Leaving a Group

You can leave the Fusion PartyBus group to play local sources on the stereo.

1 Select  > **GROUPS**.

2 Select the group you want to leave.

3 Select the stereos you want to remove from the group.

4 Select **DONE**.

## Grouped Stereo Functions

After you create a group of stereos, additional functions and options are available to all stereos in the group.

- After you create a group, all of the stereos in the group share the same synchronized display.
- You can select a source from any stereo in the group, with a few limitations (*Grouped Stereo Source Considerations, page 10*), and the source will play simultaneously on all stereos in the group (*Selecting a Source, page 3*).
- You can control playback (such as pausing and skipping tracks) on any stereo in the group, and it will affect all stereos in the group.
- You can adjust the volume for any zone on any stereo in the group.

**TIP:** When adjusting the volume, you can select ALL to adjust the volume of all the stereos in the group at the same time.

## Grouped Stereo Source Considerations

When selecting sources to play over the network, you should observe these considerations.

- Because this stereo is a zone stereo, it can create or join a group to control and play sources from other stereos, but it cannot share its sources with the group.
- You cannot share an AirPlay source with grouped stereos. Using AirPlay 2 software, you can play content on multiple stereos on the network, but the stereos must not be grouped (*Apple AirPlay, page 8*).
- You can disable sharing on most sources from other stereos on the network by changing the GROUP ENABLED setting for the sources on those stereos. When disabled, the source cannot be selected from a grouped stereo. See the owner's manual for your multi-zone Fusion Apollo stereo for instructions.
- When audio sources are streamed over a data network, there is a slight delay in the synchronized audio that may be noticeable if you are also using an external audio source.
  - If you have a television with an Optical Out connection to a stereo and you continue to use the television speakers, there will be a delay between the audio from the television speakers and the optical audio streamed on the grouped stereos.
  - If you synchronize a radio station and tune that same radio station on a non-networked stereo, there will be a delay between the audio from the non-networked stereo and the audio from the radio station streamed on the grouped stereos.
  - You can remove this delay by changing the GROUP ENABLED setting for the source, but the source cannot be shared with grouped stereos.

**NOTE:** You cannot change the settings when a stereo is part of a group. You must remove the stereo from the group before you can change any settings.

## Group Synchronization

By default, groups you create are not maintained when you turn off stereos in the group. If you turn off a single stereo added to the group, it leaves the group. If you turn off the primary stereo in the group, the group is dissolved. You can enable group synchronization to preserve group membership for a stereo after turning it off. Group synchronization behaves differently based on how you turn the stereos off and on.

- If you turn a synchronized stereo off and on by using either the power button on the stereo or a physical switch on the ignition wire (the red wire), all of the synchronized stereos in the group turn off and on together. This applies to all of the synchronized stereos in the group, whether or not a stereo is the primary stereo in the group.  
**NOTE:** Selecting ALL OFF from the power menu on a stereo turns off all stereos on the network, even if they are not in a group or have group synchronization enabled.
- If you turn a synchronized stereo off and on using a physical switch on the power wire (the yellow wire), the other synchronized stereos in the group behave differently:
  - If the synchronized stereo is the primary stereo in the group and you turn it off using a physical switch on the power wire, the other synchronized stereos in the group remain on, but leave the group. When you turn the primary stereo back on again, the other synchronized stereos rejoin the group.
  - If the synchronized stereo is not the primary stereo in the group and you turn it off and on using a physical switch on the power wire, all of the other synchronized stereos in the group remain on and grouped, and the stereo rejoins the group when you turn it on again.

## Enabling Group Synchronization

You must remove the stereo from an existing group before you can enable the GROUP SYNC setting. You cannot update settings when a stereo is part of a group.

You must enable this setting on each stereo that you want to retain group settings after a power cycle.

- 1 Select  > **SETTINGS**.
- 2 Select **POWER OPTIONS** > **GROUP SYNC**.  
The stereo retains group settings after a power cycle.
- 3 Repeat for additional stereos as needed.

**NOTE:** You must enable GROUP SYNC on all networked stereos for synchronization to work properly.

# General Settings

**NOTE:** When the stereo is in a group, you cannot change the settings on that stereo.

Select  > **SETTINGS**.

**NOTE:** When a check box is filled, the option is on. When the check box is clear, the option is off.

**DEVICE NAME:** Sets a name for this device.

**LANGUAGE:** Sets the language used on the device.

**TUNER REGION:** Sets the region used by the FM and AM sources.

**POWER OPTIONS:** Adjusts the power settings, such as the GROUP SYNC ([Power Options, page 13](#)).

**SEARCHING:** Enables Fusion Alpha Search Technology (FAST), which allows you to quickly search for tracks by letter or number. You can select a number to enable the FAST menu if your music device contains more than the selected number of items.

**ZONE:** Enables you to configure the speaker zones (, ).

**SOURCE:** Allows you to enable, disable, and name the sources and groups on the stereo ([Source Settings, page 14](#)).

**NETWORK:** Enables you to configure the Fusion PartyBus network settings ([Network Settings, page 14](#)).

**UPDATE:** Updates the stereo or connected devices using the appropriate update file on a connected USB flash drive ([Software Updates, page 19](#)).

**NOTE:** It is not necessary to use this menu if you are updating the software using the Fusion Audio app on a mobile device instead of using an update file loaded onto a USB flash drive ([Updating the Software Using the Fusion Audio App, page 20](#)).

**UPDATE > FACTORY RESET:** Restores all settings to the factory default values.

**ABOUT:** Shows the software version information for the stereo and connected accessories.

## Speaker Zone Settings

### Disabling the Internal Amplifier

If you do not connect speakers directly to the stereo, you can disable the internal amplifier to reduce power consumption.

- 1 Select  > **SETTINGS**.
- 2 Select **ZONE**.
- 3 Select **INTERNAL AMP ON** to clear the check box.

### Setting the Home Zone

The home zone is the speaker zone that you adjust by default when you turn the dial.

- 1 Select  > **SETTINGS**.
- 2 Select **ZONE > ASSIGN HOME ZONE**.
- 3 Select a zone.

### Adjusting the Power-On Volume Limit

By default, when you turn on the stereo, the system automatically reduces the volume to level 12 if it was louder than that when you turned it off. You can adjust this limit if you want to retain a louder volume or limit to a lower volume when you turn on the stereo.

**NOTE:** This setting affects all zones on the stereo.

- 1 Select  > **SETTINGS**.
- 2 Select **ZONE > POWER ON VOLUME LIMIT**.
- 3 Adjust the volume limit.



## Maintaining Individual Zone Volume Levels

If you adjust the volume levels of individual zones so that some zones are louder than others, the individual zone volume settings are all affected when you adjust the volume for ALL zones. By default, if you adjust the volume for ALL to 00, this sets of the volume levels for all zones to 00 and resets all individual zone volume adjustments. You can enable the KEEP VOLUME RATIOS option to retain individual zone volume adjustments when you adjust the volume for ALL to 00.

**NOTE:** This setting applies to volume adjustments on the stereo or a connected ERX remote control only. If you adjust the volume on the stereo using a connected chartplotter or NRX remote control, the volume levels will still be reset.

**TIP:** For the best results when enabling this setting, you should set the power-on volume limit to 24 ([Adjusting the Power-On Volume Limit, page 12](#)).

- 1 Select  > **SETTINGS**.
- 2 Select **ZONE** > **KEEP VOLUME RATIOS**.

## Setting a Zone Name

You can set a name for a speaker zone to make it easier to identify.

- 1 Select  > **SETTINGS**.
- 2 Select **ZONE**.
- 3 Select a zone.
- 4 Select **ZONE NAME**, and select an option:
  - Select a pre-defined name from the list.
  - Select **CUSTOM NAME**, and enter a unique name for the zone.

## Adjusting the Subwoofer Filter

You can use the subwoofer filter setting to control the subwoofer cutoff frequency, which can enhance the blend of the sound produced by the speakers and the subwoofer. Audio signals above the selected frequency are not passed to the subwoofer. The setting applies to both subwoofer outputs.

**NOTE:** If a DSP profile has been applied using the Fusion Audio app, this setting cannot be changed on the stereo.

- 1 Select  > **SETTINGS** > **ZONE** > **ZONE 1** > **SUB. FREQ.**.
- 2 Select a frequency.

## Adjusting Additional Audio Settings for a Zone

- 1 Select  > **SETTINGS**.
- 2 Select **ZONE**.
- 3 Select a zone.
- 4 Select one or more options:
  - To limit the maximum volume output of this zone, select **VOLUME LIMIT**, and adjust the level.
  - To adjust the right and left speaker balance of this zone, select **BALANCE**, and adjust the balance.

## Power Options

Select  > **SETTINGS** > **POWER OPTIONS**.

**POWER SAVE:** Disables the LCD backlight after one minute of inactivity to save battery power.

**GROUP SYNC:** Enables the stereo to retain group settings after a power cycle ([Group Synchronization, page 11](#)).

## Source Settings

Select  > **SETTINGS** > **SOURCE**, and select the name of the source you want to configure.

**NOTE:** This menu contains system-wide source settings. Most sources also have source-specific settings. See the sections of this manual for each source for more information about source-specific settings.

Not all options are available for every source on the stereo.

**SOURCE ENABLED:** Enables and disables the source on this stereo. You may want to disable sources that will never be used on the stereo so they no longer appear on the source-selection screen.

**SOURCE NAME:** Changes the name of the source as it appears on this stereo. This also affects how the source appears to other stereos in a group.

## Network Settings

**NOTE:** If a Garmin chartplotter is detected on the network, the stereo automatically switches to GARMIN MARINE NETWORK mode, and all other network settings are disabled.

Select  > **SETTINGS** > **NETWORK**.

**WI-FI OFF:** Turns off all Wi-Fi wireless functions.

**WI-FI CLIENT:** Configures the stereo as the wireless client, allowing it to wirelessly connect to other devices.

**WI-FI ACCESS POINT:** Configures the stereo as the wireless access point ([Wireless Access Point Settings](#), page 16).

**ADVANCED:** Allows you to set the advanced wireless and wired settings, such as DHCP and SSID ([Advanced Network Configuration](#), page 16).

**RESET:** Resets all network settings for this stereo to the factory default values.

## Connecting the Fusion PartyBus Device to a Wireless Access Point

You can connect this device to a wireless access point on a router or compatible Fusion PartyBus device on the network. This device can connect using Wi-Fi Protected Setup (WPS), if it is supported by your access point ([Connecting the Device to a Wireless Access Point Using Wi-Fi Protected Setup](#), page 14). This device can connect using Apple Accessory Configuration (WAC) using a supported Apple device ([Connecting the Device to a Wireless Access Point Using Apple Wireless Accessory Configuration](#), page 15).

1 Select  > **SETTINGS** > **NETWORK** > **WI-FI CLIENT** > **SSID**.

A list of wireless access points within range appears.

2 Select the Fusion PartyBus wireless access point.

3 If necessary, select **PASSWORD**, enter the password, and select .

4 Select **SAVE**.

**NOTE:** After you connect the stereo to a wireless access point, you cannot use the wired network connection.

## Connecting the Device to a Wireless Access Point Using Wi-Fi Protected Setup

If it is supported by your wireless access point, you can connect this device using Wi-Fi Protected Setup (WPS) instead of manually selecting the SSID and entering the password.

**NOTE:** You may need to see the owner's manual for your wireless access point for information about enabling WPS.

1 Select  > **SETTINGS** > **NETWORK** > **WI-FI CLIENT** > **WPS**.

2 Enable the WPS connection on your wireless access point.

**NOTE:** When you connect the stereo to a wireless access point, you cannot use the wired network connection.

## Connecting the Device to a Wireless Access Point Using Apple Wireless Accessory Configuration

If it is supported by Apple device, you can connect this device using Wireless Accessory Configuration (WAC) instead of manually selecting the SSID and entering the password.

**NOTE:** You may need to see the owner's manual for your Apple device for information about using WAC.

- 1 Select  > **SETTINGS** > **NETWORK** > **WI-FI CLIENT** > **WAC**.
- 2 Use your compatible Apple device to complete the connection.

**NOTE:** When you connect the stereo to a wireless access point, you cannot use the wired network connection.

## Setting the Fusion PartyBus Device as a Wireless Access Point

Before you can connect additional Fusion PartyBus devices or smartphones to a Fusion PartyBus device wirelessly, you must configure one device as a wireless access point. This is not necessary if you installed a wireless router or other wireless access point on the network.

**NOTE:** You should not configure this device as a wireless access point if you have a router installed on the network. Doing so may introduce DHCP conflicts and result in poor network performance.

- 1 Select  > **SETTINGS** > **NETWORK** > **WI-FI ACCESS POINT**.
- 2 Select an option:
  - To use factory-assigned default access point settings, select **USE DEFAULTS**, and wait for the device to save the network settings.

**NOTE:** After the default settings are saved, you can scroll down to the bottom of the **NETWORK** menu to view the SSID and password assigned to the access point.
  - To customize the access point name and security settings, select **ADVANCED**, and proceed to the next step.
- 3 Select **SSID**, and change the default SSID, or name, for the wireless access point.
- 4 Select **AP SECURITY**, and change the security type for the access point.

**NOTE:** It is strongly recommended that you use the WPA2 PERSONAL AP SECURITY setting. It is the most widely-used and secure wireless security protocol.
- 5 Select **PASSWORD**, and change the default password for the access point.
- 6 If necessary, select **COUNTRY**, and select your region.
- 7 Select **CHANNEL**, and select a channel range for the access point (optional).
- 8 Select **SAVE**.

You can adjust the wireless access point configuration at any time ([Wireless Access Point Settings](#), page 16).

**NOTE:** When you configure the stereo as a wireless access point, you can also use the wired network connection without changing any additional settings. The wired and wireless networks are bridged.

## Wireless Access Point Settings

Select  > **SETTINGS** > **NETWORK** > **ADVANCED** > **WI-FI ACCESS POINT**.

**NOTE:** You must configure the device to be a wireless access point before you can change the settings ([Setting the Fusion PartyBus Device as a Wireless Access Point, page 15](#)).

**SSID:** Sets the SSID, or name, for the network.

**AP SECURITY:** Sets the type of wireless security protocol used by the access point.

**NOTE:** It is strongly recommended that you set the AP SECURITY using WPA2 PERSONAL. It is the most widely-used and secure wireless security protocol.

**PASSWORD:** Sets the password for the access point. This is not available when the AP SECURITY setting is set to NONE.

**COUNTRY:** Sets the region where the stereo is located. Different regions may use different channels on the wireless spectrum, so you should set this to best accommodate local wireless devices.

**CHANNEL:** Sets the access point to use a group of channels in the high, low, or middle range of the available spectrum for your region. You may experience better performance if you set the channel in a range with fewer broadcasting access points.

**DHCP SERVER:** Sets the device to act as a wireless access point and the DHCP server on the network.

**WPS:** Initiates a Wi-Fi Protected Setup (WPS) connection. Devices with a WPS button or setting can connect to the access point on this stereo when the WPS connection is active.

**NOTE:** It can take up to two minutes to successfully connect to the access point after you select WPS.

## Advanced Network Configuration

You can perform advanced networking tasks on a Fusion PartyBus device, such as defining DHCP ranges and setting static IP addresses.

**NOTE:** When connected to a Garmin Marine Network via ethernet and configured as a DHCP client, the stereo automatically detects and connects to the Garmin Marine Network.

Select  > **SETTINGS** > **NETWORK** > **ADVANCED**.

**DHCP CLIENT:** Sets the device as a DHCP client. This is the default setting for all devices that are not configured to be a DHCP server or wireless access point.

**STATIC IP:** Allows you to set a static IP address for the device ([Setting a Static IP Address, page 18](#)).

**DETAILS:** Shows information about the network configuration.

## Setting the Fusion PartyBus Device as the DHCP Server

If you connected more than two network devices together using a network switch or wireless access point but you did not install a router, you should configure only one Fusion PartyBus stereo to be a DHCP server.

### NOTICE

Having more than one DHCP server on the network causes instability and poor performance for all devices on the network.

**NOTE:** If you have set up this stereo as a WI-FI ACCESS POINT, it is configured as a DHCP server by default, and no further settings changes are needed (*Setting the Fusion PartyBus Device as a Wireless Access Point*, page 15).

**NOTE:** Although the Fusion PartyBus devices can communicate with each other without a DHCP server on the network, the devices take longer to connect to each other when you first turn them on. It is highly recommended to have one properly-configured DHCP server on the network for the best results.

**1** If the device is connected to the network using an Ethernet cable, select  > **SETTINGS** > **NETWORK** > **WI-FI OFF**.

You must turn off Wi-Fi before you can set the stereo as a wired DHCP server.

**2** If the device is connected to the network using an Ethernet cable, select **STATIC IP** > **SAVE**.

You must set the stereo to use a static IP address before you can set it as a wired DHCP server.

**3** Select **ADVANCED** > **DHCP SERVER** > **DHCP ENABLED** > **SAVE**.

You can configure the IP address range of the DHCP server.

### DHCP Settings

Select  > **SETTINGS** > **NETWORK** > **ADVANCED** > **DHCP SERVER**.

**DHCP ENABLED:** Sets the device as the DHCP server on the network.

**START IP:** Sets the first IP address in the IP-address range of the DHCP server.

**END IP:** Sets the final IP address in the IP-address range of the DHCP server.

### Connecting the Stereo to a Garmin Network

**NOTE:** When you connect the stereo to a Garmin BlueNet network or a Garmin Marine Network, you are limited to using only Garmin and Fusion devices. You will not be able to use third-party routers or other network products with this stereo directly.

You cannot use Wi-Fi networking when a stereo is connected to a Garmin network using a wired network connection.

You can connect this stereo to a Garmin BlueNet network or a Garmin Marine Network in order to view and control the stereo using a compatible Garmin chartplotter.

**NOTE:** If a Garmin chartplotter is detected on the network, the stereo automatically switches to GARMIN MARINE NETWORK mode, and all other network settings are disabled.

This stereo is compatible with both Garmin BlueNet devices and Garmin Marine Network devices. For more information about Garmin BlueNet technology, including best practices for constructing a network including both Garmin BlueNet devices and Garmin Marine Network devices, go to [garmin.com/manuals/bluenet](http://garmin.com/manuals/bluenet).

**NOTE:** If your vessel has a mix of Garmin Marine Network and Garmin BlueNet networks connected through a Garmin BlueNet bridge, all stereos must be connected to the Garmin BlueNet network.

**TIP:** When the stereo is connected to a Garmin network, you can connect a mobile device to a wireless access point on a connected Garmin chartplotter and use the Fusion Audio app to control the stereo.

**1** Determine the best device on the Garmin BlueNet network or the Garmin Marine Network to which you should connect the stereo.

**2** Select an option:

- To connect the stereo to a Garmin BlueNet device, use a Garmin BlueNet network to RJ45 adapter cable (sold separately - 010-12531-02).
- To connect the stereo to a Garmin Marine Network device, use Garmin Marine Network to Fusion cables (010-12531-20) or connect the stereo to a wireless network access point on a Garmin chartplotter.

## Setting a Static IP Address

If the stereo is configured as a DHCP server, it is automatically assigned the IP address of 192.168.0.1. You can change this IP address.

If the stereo is a client on the network and you do not want the DHCP server to automatically assign an IP address to the stereo, you can set a static IP address.

**NOTE:** Every device on the network must have a unique IP address. If you select a static IP address that is the same as the IP address on the network, the devices will not work properly.

1 Select  > **SETTINGS** > **NETWORK** > **ADVANCED**.

2 Select an option:

- If the stereo is connected using an Ethernet cable, select **ETHERNET IP > STATIC IP**.
- If the stereo is set as a wireless access point or wireless client, select **WI-FI IP**.

3 Select an option:

- To set the IP address, select **IP**, and enter the IP address.
- To set the subnet mask, select **MASK**, and enter the subnet mask.

**NOTE:** The subnet mask must match all other devices on the network to work properly. A typical subnet mask is 255.255.255.0.

- To set the default gateway IP address, select **GATEWAY**, and enter the gateway IP address.

**NOTE:** The default gateway is typically set as the IP address of the DHCP server on the network.

4 Select **SAVE**.

## Resetting Network Settings

You can reset all network settings for this stereo to the factory default values.

1 Select  > **SETTINGS**.

2 Select **NETWORK > ADVANCED > RESET > YES**.

# Additional Stereo Control Options

## Fusion Audio Wireless Remote Control App

You can use the Fusion Audio remote control app on your compatible Apple or Android device to adjust the stereo volume, change the source, control playback, select and manage radio presets, and adjust some stereo settings. You can use the app to set up and configure DSP profiles on the stereo. You can use the app to update the stereo software.

The app communicates with the stereo using a wireless connection to the mobile device. You must connect your compatible device to the stereo using Bluetooth or Wi-Fi technology to use the app.

If the stereo is connected to a network with a Wi-Fi access point, the app can communicate with the stereo using the network for greater range than a Bluetooth connection.

**NOTE:** You cannot update the stereo software using a Bluetooth connection. You must connect the app using a Wi-Fi connection to update the stereo software wirelessly.

For information about the Fusion Audio remote control app for compatible Apple or Android devices, go to the Apple App Store<sup>SM</sup> or the Google Play<sup>TM</sup> store.

## Fusion Stereo Network Connection and Control

When connected using a supported networking method, you can fully control compatible Fusion entertainment systems on compatible multi-function displays installed at the helm, flybridge, or navigation station of the vessel. This provides integrated entertainment control and a less cluttered console.

The connected multi-function display becomes the portal on which you can control all audio on the vessel, no matter where on the vessel the connected stereo is installed. The compatible Fusion stereo can be installed out of sight if space is an issue and users need to access the stereo only to replace removable media.

This device can communicate with a compatible multi-function display using existing industry-standard network connections including Ethernet and Wi-Fi wireless technology.

**NOTE:** Garmin multi-function displays must be connected via Ethernet.

## Appendix

### Registering Your Fusion Device

Help us better support you by completing our online registration today.

- Go to [garmin.com/account/register](https://garmin.com/account/register).
- Keep the original sales receipt, or a photocopy, in a safe place.

### Cleaning the Device

- 1 Dampen a soft, clean, lint-free cloth with fresh water.
- 2 Gently wipe the device.

### Software Updates

For best results, you should update the software in all Fusion devices at the time of installation to ensure compatibility.

You can update the software using the Fusion Audio remote control app on your compatible Apple or Android device. To download the app and update the device software, go to the Apple App Store or the Google Play store.

## Updating the Software Using the Fusion Audio App

You must connect the Fusion Audio app to the stereo or to Fusion PartyBus network using a wireless router or wireless access point to transfer a software update to the stereo. You cannot update the software using a Bluetooth connection.



**NOTE:** If the stereo you want to update is in a group, you must remove it from the group (*Leaving a Group*, page 9).

If the stereo has a wireless access point or is connected to a Fusion PartyBus network with a wireless router or wireless access point, you can update the stereo software using the Fusion Audio app, available for compatible Apple or Android on the Apple App Store or the Google Play store.

### NOTICE

Do not turn off the device or disconnect the power during a software update. Turning off the power during a software update may cause the device to become unresponsive.

#### NOTE:

- The device may restart a few times while updating the software. This is expected behavior.
  - You can program only newer versions of software on the device.
- 1 If necessary, connect your mobile device to the stereo using one of these methods:
    - Connect your device to the stereo using a Bluetooth connection.  
**NOTE:** You can use a Bluetooth connection to access the stereo and allow the app to download an update, but you must switch to a Wi-Fi connection to transfer the update to the stereo.
    - Connect your device to the stereo using a wireless access point on the stereo.
    - Connect your device to a wireless router or wireless access point on the same Fusion PartyBus network as the stereo.
  - 2 Open the Fusion Audio app, and verify that you can see the stereo in the app.
  - 3 If you connected directly to a wireless access point on the stereo or if the Fusion PartyBus network is not connected to the internet, disconnect the mobile device from the wireless router or access point and connect it to a Wi-Fi network with internet access or to the wireless mobile data connection from your carrier.  
**NOTE:** You must connect your mobile device to the internet in order to download the necessary software update files.
  - 4 In the Fusion Audio app, select  > **GENERAL** > **Software Update**.
  - 5 Select the **Online Software Update**.  
The app downloads the software update file.
  - 6 If necessary, after the app finishes downloading the update file, reconnect the mobile device to the wireless access point on the stereo or to a wireless router or access point on the Fusion PartyBus network.
  - 7 If necessary, in the Fusion Audio app, reconnect to the stereo.
  - 8 If necessary, select  > **GENERAL** > **Software Updates** > **Online Software Update**.  
The app transfers the software update to the stereo over the Wi-Fi network, the stereo updates the software, and then it restarts.

## Network Update Options

When connected to the same Garmin BlueNet network or Garmin Marine Network as a compatible Garmin chartplotter, you can update your compatible Fusion stereos and accessories from the chartplotter.

You can perform a Garmin network update which updates all of the of Garmin and Fusion devices connected to the network.

## Troubleshooting

### The stereo does not respond to key presses

- Press and hold  for at least 10 seconds to reset the stereo.



## My Bluetooth audio is interrupted by short breaks

- Ensure the media player is not covered or obstructed.  
Bluetooth technology performs best with line-of-sight operation.
- Bring the media player within 10 m (33 ft.) of the stereo.
- Turn off the **DISCOVERABLE** setting after pairing a Bluetooth device to the stereo.
- Wi-Fi signals may interfere with Bluetooth device connections. You should turn off the Wi-Fi setting on your stereo if you are not using it.

## The stereo does not display all song information from my Bluetooth source

The availability of song information such as song title, artist name, track duration, and album cover artwork depends on the capability of the media player and music application.

## Network Troubleshooting

If you cannot see or connect to Fusion PartyBus devices on the network, perform these steps.







- Verify that all Fusion PartyBus devices, network switches, routers, and wireless access points are connected to the network and turned on.
- Verify that wireless Fusion PartyBus devices are connected to a wireless router or wireless access point on the network.

**NOTE:** Wired connections are more reliable than wireless connections. If possible, you should connect devices to the network using an Ethernet cable.

- Verify that only one device, either a stereo or a router, is configured as a DHCP server.
- Change the channel on your router or wireless access point to test for and correct interference.  
You may experience wireless interference if there are many nearby wireless access points.
- Disconnect Bluetooth devices to test for and correct interference.  
Connecting a Bluetooth device to a stereo configured as a wireless access point or client may reduce wireless performance.
- If you are experiencing trouble connecting, make sure your router supports 2.4 GHz band connections.  
When connecting to a wireless router, this device is compatible with only 2.4 GHz band connections, and cannot connect to a 5 GHz band.
- If you configured static IP addresses, verify that every device has a unique IP address, that the first three sets of numbers in the IP addresses match, and that the subnet masks on every device are identical.
- If you have made configuration changes that might be causing networking issues, reset all network settings to the factory default values.

## Network Status Icons

A network-status icon is shown on some screens of the stereo. You can refer to this table to understand the appearance of the icon and help diagnose issues with the Fusion PartyBus network.

	The stereo is configured for a wired network connection and connected to a wired network using an Ethernet cable.
	The stereo is configured for a wired network connection, but cannot detect the wired network. An Ethernet cable may not be connected or there may be other problems with the network.
	The stereo is in Wi-Fi accessory configuration (WAC) mode, which allows for an easy connection to Apple devices.
	The stereo is configured as a wireless access point.
	The stereo is configured as a wireless client and connected to a wireless access point. The number of bars indicates the signal strength.
	The stereo is configured as a wireless client, but is not connected to a wireless access point. There may be a problem with the connection settings or with the wireless access point.

## The stereo keeps locking up when connected to an Apple device

- Press and hold the power button to reset the stereo.
- Reset the Apple device. Go to [www.apple.com](http://www.apple.com) for more information.
- Make sure you have the latest version of iTunes® and the latest operating software on your Apple device.

## The stereo is not finding my connected Apple device

- Make sure your Apple device supports Interface Accessory Protocol 2 (iAP2). This stereo is not compatible with iAP1 devices.
- Make sure you have the latest version of iTunes and the latest operating software on your Apple device.
- Make sure you have the latest version of the Fusion Audio application on your Apple device.
- Reset the Apple device.  
Go to [apple.com](http://apple.com) for more information.
- Contact your Fusion dealer or go to [support.garmin.com](http://support.garmin.com).

## My Apple AirPlay audio is interrupted by short breaks

- Make sure the Apple device is not covered or obstructed.
- Make sure the Apple device has a good connection to the same Wi-Fi network as the stereo.
- Make sure the Apple device is not connected to the stereo using Bluetooth technology and Wi-Fi.  
Using both a Bluetooth and a Wi-Fi connection may cause playback interruptions.

# Specifications

## General

Weight	340 g (12.0 oz.)
Water resistance	IEC 60529 IPX7 (front of stereo only, when properly installed)
Operating temperature range	From 0 to 50°C (from 32 to 122°F)
Storage temperature range	From -20 to 70°C (from -4 to 158°F)
Input voltage	From 10.8 to 16 Vdc
Current (max.)	8 A
Current (muted)	Less than 400 mA
Current (off)	Less than 200 mA
Fuse	15 A blade type
Wi-Fi wireless range	Up to 32 m (105 ft.)
Bluetooth wireless range	Up to 10 m (30 ft.)
Wireless frequencies/protocols	Wi-Fi 2.4 GHz @ 15 dBm nominal Bluetooth 2.4 GHz @ 10 dBm nominal
Compass-safe distance	10 cm (3.9 in.)

## On-board, Class D Amplifier

Output music power per channel	70 W max. x 2 at 2 ohm per channel
Total output peak power	140 W max.
Output power per channel <sup>1</sup>	2 x 43 W RMS at 14.4 Vdc input, 2 ohm, 10% THD 2 x 26 W RMS at 14.4 Vdc input, 4 ohm, 10% THD

## Tuner frequencies

Tuner	Europe and Australasia	USA	Japan
FM radio frequency range	87.5 to 108 MHz	87.5 to 107.9 MHz	76 to 95 MHz
FM frequency step	50 kHz	200 kHz	50 kHz
AM radio frequency range	522 to 1620 kHz	530 to 1710 kHz	522 to 1620 kHz
AM frequency step	9 kHz	10 kHz	9 kHz

<sup>1</sup> The stereo may limit the output power to prevent the amplifier from overheating, and to maintain the audio dynamics.

# Stereo Dimension Drawings

## Side Dimensions

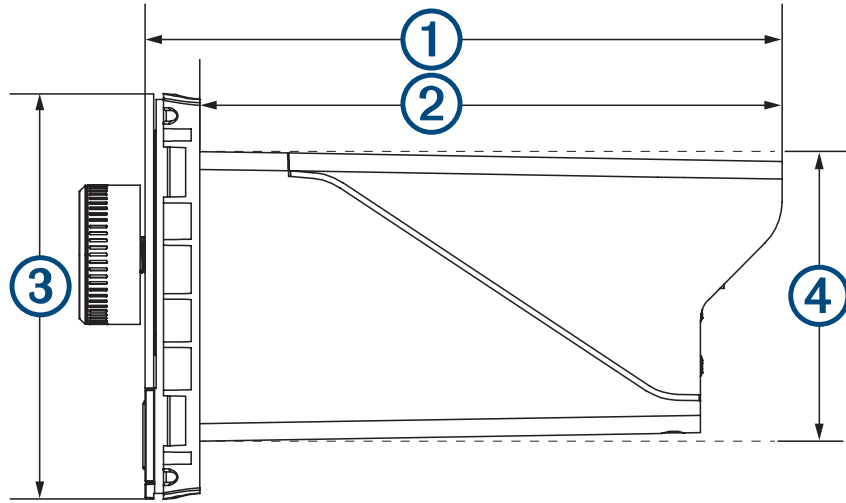

①	110 mm (4.33 in.)
②	100 mm (3.94 in.)
③	70 mm (2.76 in.)
④	50 mm (1.97 in.)

## Top Dimensions

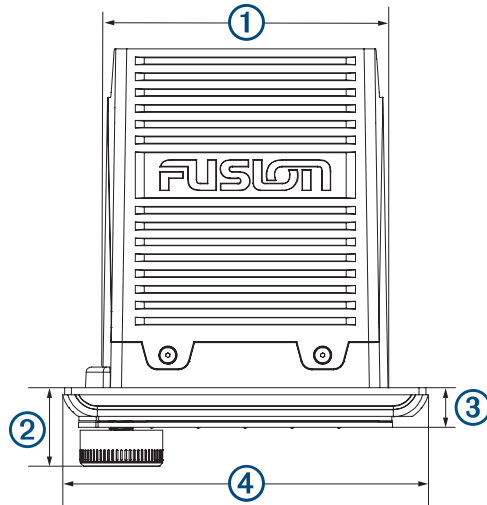

①	83 mm (3.27 in.)
②	22 mm (0.87 in.)
③	10 mm (0.39 in.)
④	110 mm (4.33 in.)

